

# Framery One™



The smart and soundproof office pod  
shaping the workplace of tomorrow



Framery One is a smart, spacious, one-person workstation designed for video calls and focus work. Contemporary design and advanced technology characterize every detail of this comfortable and versatile workspace. This soundproof office pod features world-class sound insulation, industry-leading ventilation, and echo-free acoustics so you can focus on your work and connect online with people anywhere.

## Framery One / Product highlights



### Workdays that flow with ease

Framery One has been purposefully designed to make your workdays flow easier. Automatically reserve a vacant pod by stepping inside, or book it in advance from the Framery app. Extend your reservation directly from the pod's touchscreen, or adjust your booking through the app.



### Privacy you can trust

A-Class soundproofing assures that Framery pods can be placed next to workstations without causing noise distractions to the person in the pod or to the people outside. And echo-free interior acoustics make Framery One a private, comfortable place for work and video calls.



### Airflow that keeps you fresh

Stay fresh and focused with efficient airflow. Enhanced ventilation fully refreshes the air every minute. The ventilation can be easily adjusted to the user's preferences through the pod's touchscreen display with a single touch.



### Lighting that makes you feel good

Automated dual-lighting sources adapt to your needs, with preset lighting options to choose between work or video modes. Video-optimized lighting helps you shine on video calls. Adjustments can be made quickly and easily through the touchscreen display.

## Framery One / Tech features



### 1. A-CLASS SOUNDPROOFING

Guaranteed privacy with an industry leading Class A speech level reduction of 30dB and one of the industry's top ISO 23351-1 ratings for office phone booths.

### 2. ADJUSTABLE VENTILATION

Proprietary design enables unparalleled ventilation with maximum airflow of 29 l/s – surpassing industry standards around the world.

### 3. OPTIMIZED LIGHTING

Dual adjustable 4000K LED light sources allow you to seamlessly switch between video or work modes – or make manual adjustments for personalized illumination.

### 4. AUTOMATED WALK-IN RESERVATIONS

Step inside the pod to create an automatic walk-in reservation – or easily find and book Framery One through the Framery app. Adjust your booking from the mobile application, or directly from inside the pod.

**5. BUILT-IN 4G CONNECTION**  
Framery smart pods come with built-in 4G connection enabling over the air software updates and keeping your pods connected to your calendar.

### 6. INTUITIVE UI

A high-resolution touchscreen makes it easy to control pod settings, adjust lighting and airflow, and manage calendar reservations.

### 7. AUTOMATIC UPDATES

A built-in 4G connection enables automatic over-the-air software updates – initiated instantly and silently in the background.

### 8. OCCUPANCY INDICATION

The side-mounted occupancy lights show at a glance whether the pod is free or already in use. The pod's usage data is gathered and visualized in Framery Connect™ to help ensure you have the right number pods, and that they are placed correctly in your office.

### 9. FRAMERY CONNECT™

Gain insights from occupancy data, initiate advanced bookability functionalities, and connect your Framery One to the entire office to get valuable usage data needed to improve the layout and efficiency of your workplace.

### 10. BOOKABLE PODS

Make your smart pod bookable like any meeting room. The pod's touchscreen will show reservations and you can manage them on the spot.

---

## Framery One / Design details

Contemporary design and advanced technology characterize every detail of this comfortable and stylish soundproof pod that is built sustainably and engineered to last. Framery One is available in three distinct layouts, each designed to support a different way of working. Whether you need ergonomic adjustability, relaxed comfort, or open flexibility, there's a configuration to match your workday rhythm.



Ideal for tasks that require extended focus, Framery One is available with an electric work desk, a built-in height-adjustable stool, and dual footrests to support ergonomic working positions, and allow users to fine-tune their setup for comfort and concentration.



For more relaxed experience, an optional built-in sofa and curved desk create a comfortable, informal workspace that is well-suited for virtual meetings, solo work, or quiet moments between tasks. The table can be upgraded to an electric work desk.



The exterior occupancy lights show at a glance whether the pod is available or already taken.



Customize your pod to fit your workplace with over 3000 combinations of colors, fabrics, and high-quality materials to choose from.



An optional monitor wall mount lets you add a full-sized display for additional flexibility.

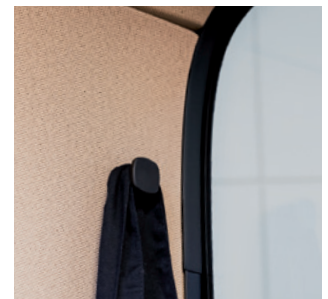

Convenient outlets and a coat hook are provided to accommodate all your office accessories.

# Framery One / Colors and finishes



## EXTERIORS

	White (Standard) RAL 9016 Ultramatt
	Black (Standard) RAL 9005 Ultramatt
	Gray (Standard) S 7500 - N Ultramatt
	Navy S 7020 - R90B Ultramatt
	Sand S 2010 - Y20R Ultramatt
	Powder Blue 3421-R86B Ultramatt
	Winter Moss S 7010-G10Y Ultramatt
	Blush 2728-R01B Ultramatt

## CARPETS

	Light Gray (Standard) Fletco carpets
	Dark Blue Fletco carpets
	Champagne Fletco carpets
	Grape Fletco carpets





## TABLE TOPS

	White (Standard) White laminate
	Black Black Laminate with anti-fingerprint surface
	Oak Veneer

## SEATING FABRICS

	Graphite (Standard) Select #60051 Gabriel
	Dark Blue Select #66144 Gabriel
	Grape Select #61190 Gabriel
	Rose Select #65117 Gabriel
	Powder Blue Select #67098 Gabriel
	Beige Select #61184 Gabriel
	Green Select #68209 Gabriel
	Mustard Select #62098 Gabriel

## INTERIORS

	Pure Gray (Standard) Tonal #60123 Gabriel
	Arctic Blue Tonal #66185 Gabriel
	Sand Tonal #61180 Gabriel
	Rouge Tonal #64210 Gabriel

## MATERIALS AND FINISHES



**EXTERIOR PANELS** made from steel feature a powder-coated matt finish. The lightweight panels are joined together seamlessly, with elegant curves that create a timeless design.



**INTERIOR PANELS** made from high-quality and recycled polyester have a vibrant and dynamic look thanks to the mix of the two-colored fabric.

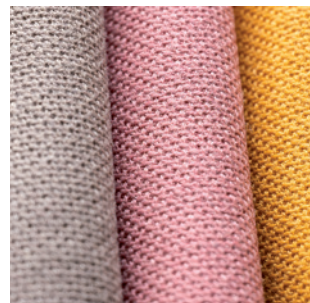

**SEATING MATERIALS** are a blend of superior New Zealand wool and polyamid that form a soft and rich texture. The extremely durable fabrics are both dirt and water repellent.



**CARPET FLOORING** is anti-static, stain resistant, and durable, giving the pod an overall soft look and finish.

---

## Framery smart office solutions / Set your office up for success

Framery's smart solutions boost productivity and flexibility with intuitive workplace tech. Enhance the employee experience with seamless room booking, access workplace-wide insights, and make data-driven decisions. Book any space instantly—on-site or on the go.

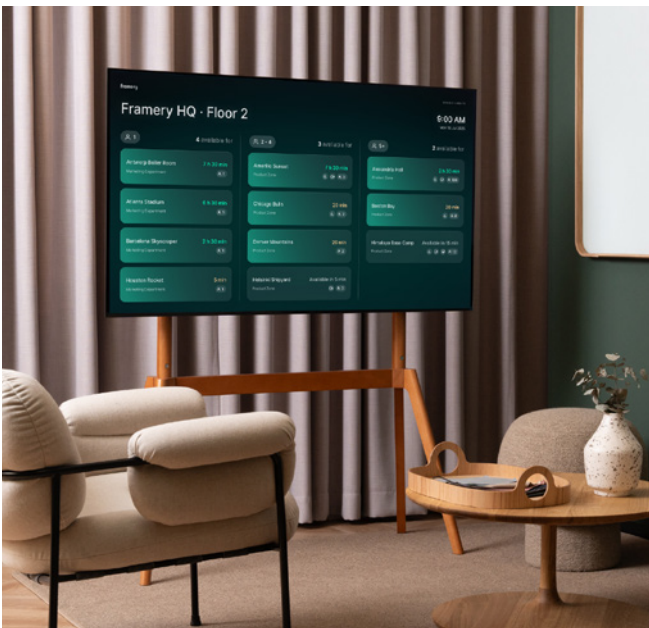

NEW

### Framery Space Overview™

**ROOM BOOKING SOLUTIONS** Framery Space Overview shows real-time space availability across nearby workspaces. Employees can instantly view which spaces are free, along with their location and capacity, and book them directly.

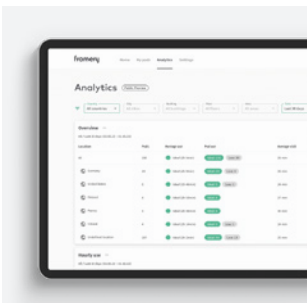

### Framery Connect™

**WORKPLACE MANAGEMENT**  
A smart platform for workplace management.



### Framery Connect Sensor™

**WORKPLACE MANAGEMENT**  
Collect usage data from any space.

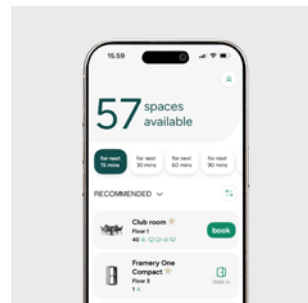

### Framery App™

**ROOM BOOKING SOLUTIONS**  
Find and book spaces in seconds.

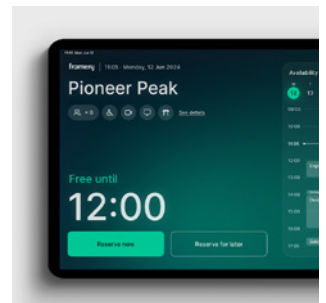

### Framery Room Display™

**ROOM BOOKING SOLUTIONS**  
See availability and book any room with ease.

### Unparalleled support

Get instant support from a Framery specialist for any issues that may arise with your smart pods or other products.

### Automatic updates

Instantly receive software updates through your smart pod's 4G connection to enable the future developments.

### Privacy assured

No identifiable user data is collected—only workspace occupancy information is tracked.

---

## FRAMERY PLUS—EVERYTHING YOU NEED FOR A SUCCESSFUL WORKPLACE

Unlock all the tools and features your workplace needs to thrive with our subscription based Framery Plus™—new smart pod customers receive a complimentary 1-year subscription.

# Framery smart pods / Environmental data sheet

Framery's new smart pods set the standard in sustainability – with durability that is measured in decades, light-weight product structures, use of truly recyclable materials, and modularity that allows the life cycle of the products to be extended indefinitely. Framery participates in the Science Based Targets initiative, and has set emission reduction targets aligned with the goal of limiting global warming to 1.5°C compared to pre-industrial levels.



## Optimal material use

Framery has achieved a 23% material reduction with its new line of products – which equals over 1 million kg of raw material annually – while increasing their level of performance compared to previous models. The carbon footprint in the manufacturing stage of the new products is 16% smaller on average. A change from plywood to steel as the main construction material also allows Framery to continue reducing its environmental impact and strive towards a 50% reduction in product CO2 emissions by 2028.



## Production and waste management

All our pods are manufactured in Tampere, Finland using zero-emission electricity. Our factory logistics are operated on biogas and renewable diesel. The material efficiency rate of our production was 94.9% in 2022. Virtually no waste goes to landfill.



## Environmental impact

We have conducted life cycle assessment studies for our products to measure their environmental

impacts. Alongside their carbon footprint, we also study other impacts such as resource depletion and water scarcity. The results are verified by an independent third party, and then published and registered as an EPD to provide stakeholders with reliable information on our products' environmental performance in a transparent way.



## Product performance

The modular design of our pods facilitates a long product lifetime, and our customers typically use them for many years. The same pod can be used by one customer after another, enabling multiple life cycles and saving valuable resources. Thanks to their modular design, our pods are easy to disassemble, refurbish if needed, and reassemble at a new location. Our products are GREENGUARD Gold certified, and highly maintainable with easily available spare parts.

## Materials

To increase circularity, the pods contain mono-materials rather than composites for 100% recyclability. They also contain more recycled materials, including 20% recycled steel and aluminum, 29% recycled glass, and fabric featuring 80% recycled plastic. Framery will also be among the select few companies in the world pioneering the use of SSAB fossil-free steel in our products, starting as soon as the material becomes available in 2026.



## Certificates and studies available

- Life Cycle Assessment (LCA)
- Environmental Product Declarations (EPD)
- Health Product Declarations (HPD) & Declare labels
- UL GREENGUARD Gold
- Contribution to Green Building Certifications such as LEED, BREEAM, SKA and WELL

100% END OF LIFE  
RECYCLABILITY  
\*Framery One 95%



80 %  
RECYCLED PET



20 %  
RECYCLED STEEL



29%  
RECYCLED GLASS



CERTIFIED  
TEXTILES



CERTIFIED  
WOOD

# Framery One™

## Technical specifications

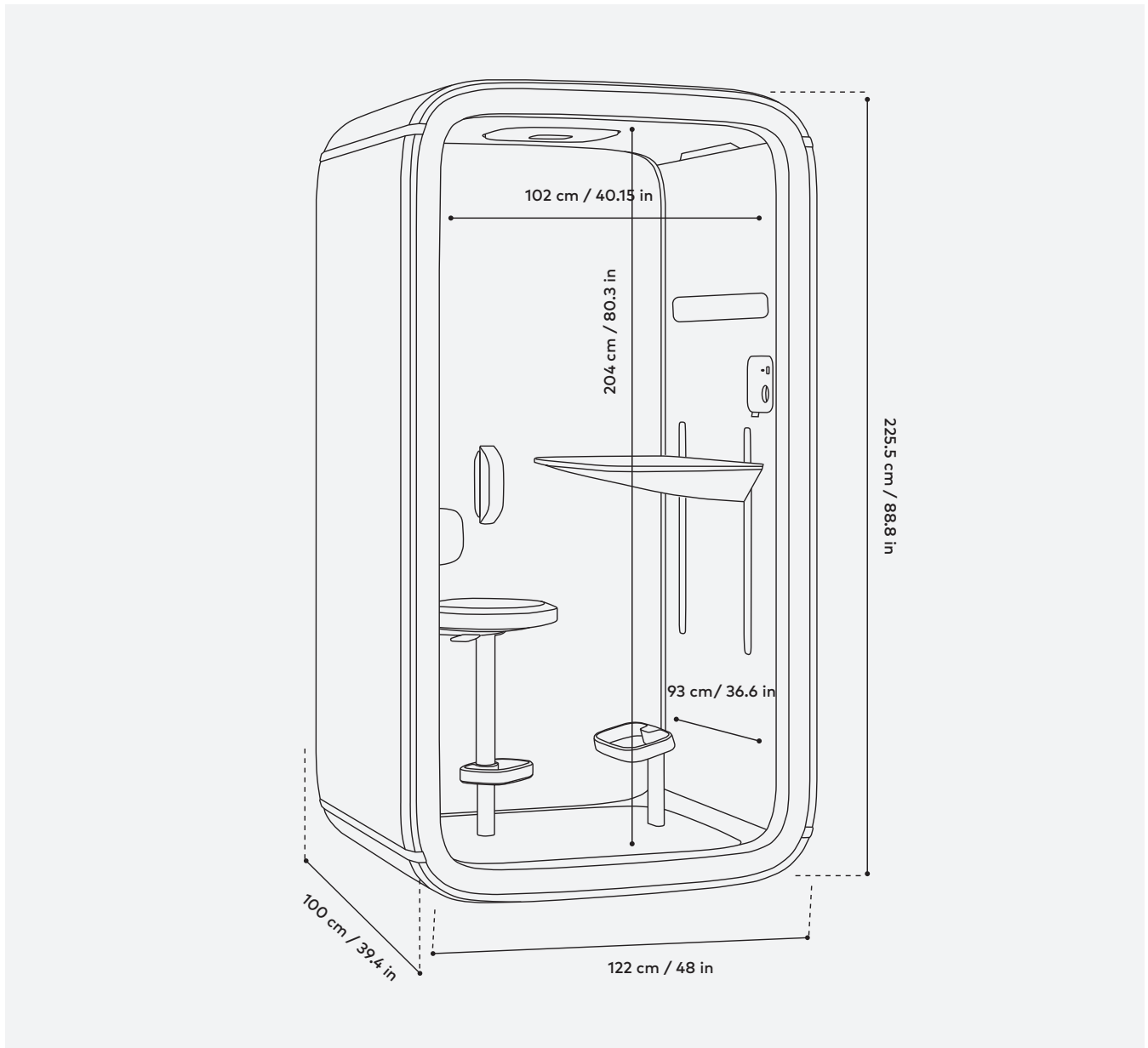

### Performance

Speech level reduction: 30dB  
Max airflow: 26 l/s  
Low energy consumption: 28W

### Sustainable design

Built to last for decades  
Light-weight product structures  
Refurbishable & movable

### Connectivity

Built-in 4G connection  
Automatic software updates  
Framery Connect digital services

# Framery One / Technical specifications

## OVERVIEW

Soundproofing	<b>CLASS A 30 DS,A (dB) reduction</b> Speech level reduction DS,A (dB) is measured using ISO 23351-1. Pod can be placed next to workspaces without compromising privacy.
Ventilation	<b>DEFAULT AIRFLOW 26 l/s, 55 CFM (94 m<sup>3</sup>/h).</b> Airflow can be adjusted manually. After use, the pod refreshes itself with a higher ventilation speed. <b>STANDBY MODE 7 l/s, 15 CFM, (25 m<sup>3</sup>/h)</b>
Lighting	<b>CEILING LIGHT</b> Color temperature 4000 K, illuminance up to 500 lux on the tabletop. <b>VIDEO LIGHT</b> Color temperature 4000 K, illuminance up to 400 lux on the user's face. <b>PRE-SET LIGHTING MODES</b> Standard mode & Video call mode. Lighting can also be adjusted manually.
Presence detection	<b>SENSOR TECHNOLOGY</b> Ultrasonic sensor
Dimensions	<b>EXTERIOR</b> 225.5 x 122 x 100 cm / 88.8 x 48 x 39.4 in (h, w, d) <b>WITH CASTERS</b> Additional 3 cm / 1.18 in (h) <b>WITH AIR FILTER</b> additional 6.5 cm / 2.56 in (h) <b>WITH SEISMIC KIT</b> additional 2 cm / 0.78 in (h) <b>DOORWAY</b> 204 x 101.5 cm / 80.3 x 40 in (h, w) <b>WEIGHT</b> 357 kg / 787 lb (Framery One Lounge: 370 kg / 815.7 lb) <b>THRESHOLD</b> 11 cm / 4.35 in (with casters 12.3 cm / 4.85 in)
Connectivity	Framery smart pods gather anonymous occupancy data, measuring when and how often spaces are used. Users in the space cannot be identified and no personally identifiable data is collected. The anonymous data is transferred via built-in 4G connectivity, and compiled and shown in the Framery Connect platform.

## DIMENSIONS / MAIN VIEW

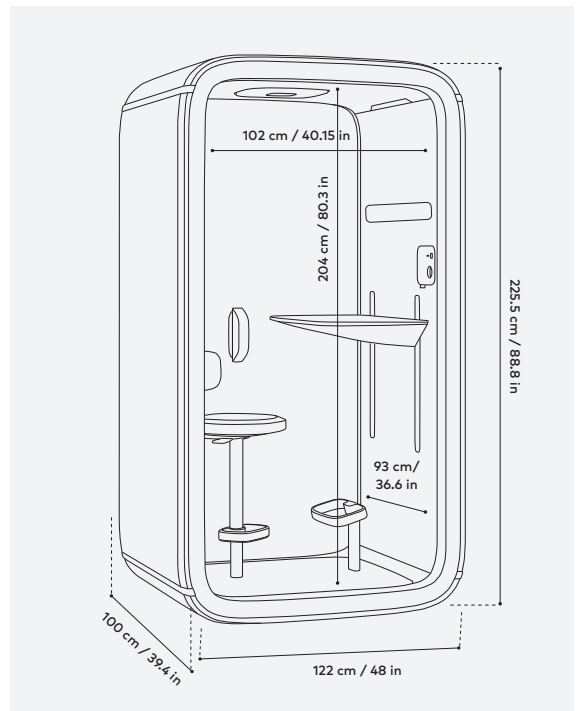

## DIMENSIONS / HEIGHT ADJUSTABLE SEAT AND TABLE / FRONT VIEW

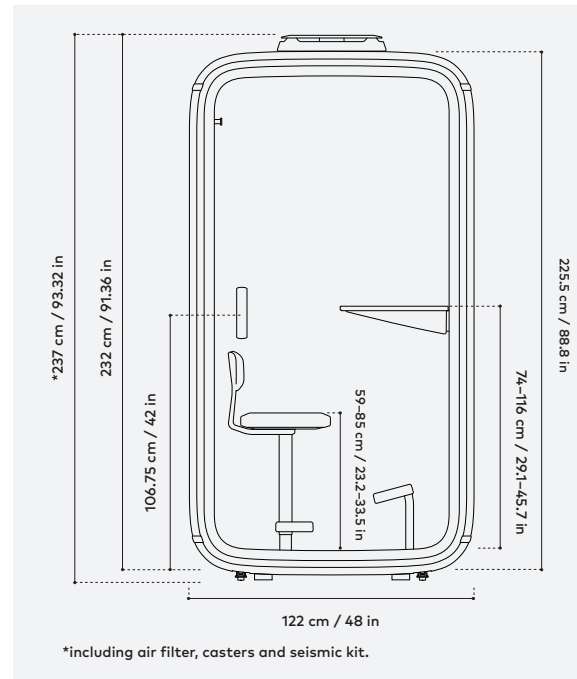

# Framery One / Technical specifications

## MATERIALS

**Exterior & structure**

**EXTERIOR PANELS** Powder coated matt steel panels

**FRAMES** Structure matt black frames made from steel & aluminum

**DOOR FRAME** Matt black composite structure

**GLASS** Sound control laminated glass (4 + 4 mm / 0.16 + 0.16 in.)

**CHASSIS** A sandwich element chassis, made of sheet metal & recycled acoustic foam

**HANDLE** Black cast aluminum

**Interior materials**

**INTERIOR PANELS** PET sheets which are laminated with recycled polyester fabric

**UPHOLSTERY FABRIC** Gabriel Tonal

**CARPET** Antistatic and stain resistant low loop pile carpet

**TABLE** Table top is birch plywood laminated with white, black anti-fingerprint, or oak veneer. The table bottom is black thermoformed felt

**Seating materials**

**UPHOLSTERY FABRIC** Gabriel Select

**FABRIC COMPOSITION** 85 % New Zealand wool / 15 % Polyamide

**STOOL & FOOTREST** Steel, aluminum & plastic (Carpet also included for the Framery One Lounge footrest)

**Furniture dimensions**

**TABLE SIZE** 76.5 x 46 cm / 30.1 x 18 in (w, d)

**TABLE HEIGHT** 74–116 cm / 29.1–45.7 in (Framery One Lounge with fixed table 88 cm / 34.6 in)

**MAX LOAD FOR THE TABLE** 50 kg / 110 lb

**SEAT SIZE** 38 x 38 cm / 15 x 15 in (d, w) (Framery One Lounge 40.2 x 60.7 cm / 15.8 in x 23.9 in)

**SEAT HEIGHT** 59–85 cm / 23.2–33.5 in (Framery One Lounge 62 cm / 24.4 in)

**MAX LOAD FOR THE SEAT** 135 kg / 300 lb (Framery One Lounge 200kg / 441 lb)

**Optional accessories**

**MONITOR WALL MOUNT** Maximum monitor size 24". Maximum weight 5 kg / 11 lbs with flat VESA 100 x 100 mounting surface. Monitor not included.

## SHIPPING CRATE

**Dimensions**

229 x 131 x 88 cm / 90.15 x 51.6 x 34.6 in (Framery One Lounge also includes a second crate 80 x 60 x 70 cm / 31.5 x 23.6 x 27.6 in.)

**Weight**

430 kg / 948 lb (Framery One Lounge 464 kg / 1023 lb). Crates can be stacked (max 3 boxes).

## DIMENSIONS / HEIGHT ADJUSTABLE SEAT AND TABLE / TOP VIEW

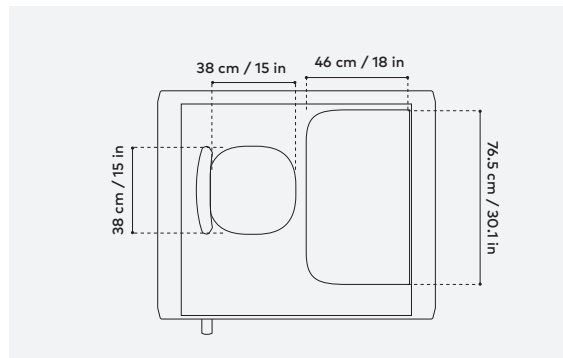

## DIMENSIONS / LOUNGE SEAT AND FIXED TABLE / FRONT VIEW

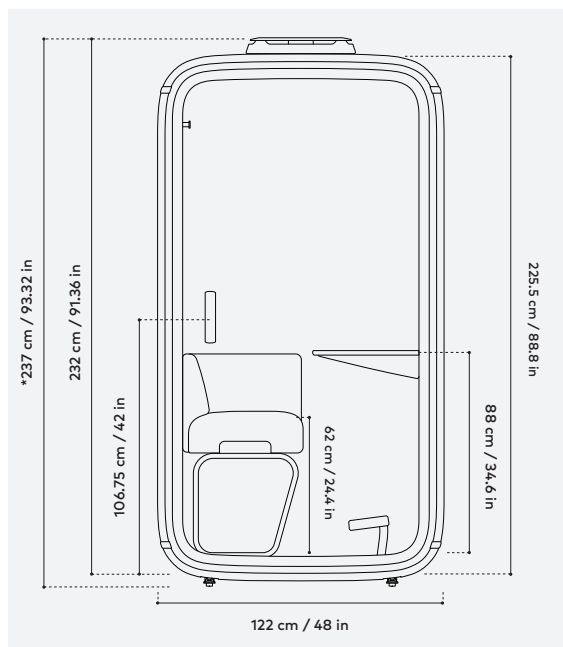

## DIMENSIONS / LOUNGE SEAT AND FIXED TABLE / TOP VIEW

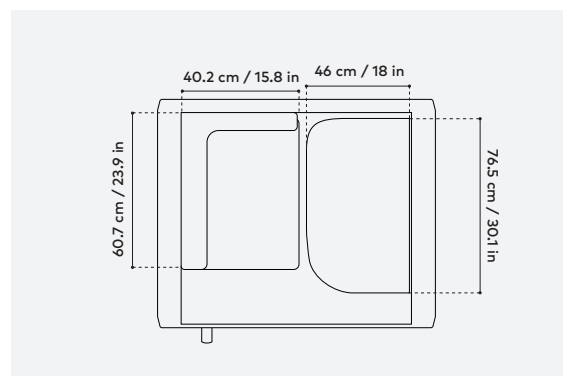

# Framery One / Technical specifications

## POWER AND SPACE REQUIREMENTS

Power	<b>OUTLETS</b> 1 × power outlet, 1 × USB-C charge port (15W) Optional: 1 × LAN port (with cable)  <b>POWER CONSUMPTION</b> Default settings 28W. Highest settings 37W Standby mode 6W  <b>INPUT</b> 100–240 VAC, 10 A*, 50–60 Hz  <b>OUTPUT AC (POWER OUTLET)</b> 100–240VAC, 6.6A, 50–60 Hz  <b>OUTPUT USB-C CHARGE PORT 15W</b>
-------	---

\*In India power outlet type 16A is used

Space requirements	<b>DOOR SWING ANGLE 90°</b>
Door handedness	Right-handed by default (can also be installed left-handed)
Operating space	From back to front (pod depth + doorway): 201.5 cm / 79.4 in. Room height requirement: 240 cm / 94.5 in. For seismic anchoring or sprinklers leave 50 cm / 19.7 in of free space around the sides of the pod. The pod can be anchored next to the wall with optional casters.
Installation space	Installation requires 50 cm / 19.7 in of free space around the pod
Movability	Relocate the pod without the need for disassembly by adding casters (optional). Levelling guides must be lifted when moving the pod, and lowered when placed in position.

## SAFETY

Fire safety	No fire hazardous materials are used in Framery pods. The fire safety of all surface materials, upholstery and acoustics materials of our products are tested and classified by either national or international standards. Framery provides additional safety measurements to adhere to local regulatory requirements.
Seismic safety	A seismic anchoring kit for a pod is available for the seismic regions. The kit consists of brackets that further reinforce the pod structure to withstand heavy seismic forces.

## DIMENSIONS / POWER CORD SPECIFICATIONS

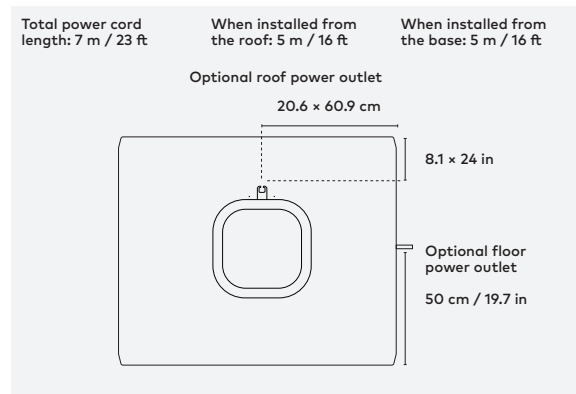

## DIMENSIONS / OPERATING SPACE

