



Environmental Memory- LOTTUS

Environmental Memory – LOTTUS

Index

1. General Information	Pág. 03
2. Enea with the environment	Pág. 03
3. LOTTUS: aspects of environmental innovation	Pág. 04
3.1. Specifications of the product	Pág. 04
3.2. LOTTUS life's cycle	Pág. 05
3.3. Environmental impacts	Pág. 06
3.4. Instructions for end-of-life of the product	Pág. 07
3.5. Additional environmental information	Pág. 08

1. General information

Product: LOTTUS

Designer: LIEVORE, ALTHERR, MOLINA

2. Enea with the environment

ENEA started in 1984 focused to manufacture and market contemporary design furniture. During all these years it had an excellent evolution, with an important presence in the world market furnishing lots of unique buildings in the hands of renowned architects.

The company, in the manufacture of its products, shows its concern for the natural environment through a philosophy of design and production where the following environmental criteria are taken into account:

- **Simplicity:** during the design process seeks to minimize the number of components, achieving a perfect interplay between them.
- **Recycling and reuse:** design seeks the use of recyclable and recycled materials for their manufacture, as well as easy removal that would facilitate the recycling and reuse.
- **Use of non-dangerous materials:** ENEA also works to reduce and replace the use of dangerous materials or negative for the environment. For example, using epoxy paints that are free from solvents and compounds volatile organic harmful.

ENEA uses a few production processes of high technology, in addition to an intense process of research and adaptation of materials to the needs of use. Various processes have been submitted from the beginning to a rigorous policy of quality, what has led to the company to be one of the first Spanish companies, manufacturers of furniture design, in obtaining the **ISO 9001 quality certification** and certificate of the **system of management of ecodesign**, awarded by AENOR, complies with the **UNE-EN ISO 14.006** and the certificate of the system of environmental management according to the **quality certification UNE-EN ISO 14001**.

All these processes, controls and selection of materials, guarantee the high quality of the products of ENEA, both in strength and durability as its finish, but with the commitment to achieve all this, taking into account the environment, framed within sustainable development. The objective is always meet current needs without compromising future resources.

3. LOTTUS, aspects of environmental innovation

Lottus Chair, designed by Lievore Altherr Molina follows the line and style of stool Lottus. It is a program of seats formed by monoshells of injected polypropylene which combine color and upholstery in the seat. The design permits that it can be mounted on different metal structures of painted tube: 4 legged stackable with and without arms, stackable cantilever and swivel central base, with wheels, as well as 3 different types of armrests: steel, aluminium and wing arm. Family evolves presenting Lottus Spin versions, fixed and rotating 4 feet and the child version. Lottus Chair is also available with fully upholstered and Oak veneered shells. Its necessary to add a version of chair with high back HIGH, a new aluminum base for Office chair, wood structure and wood shell in 2D and 3D. All this added to their contained dimensions, its studied ergonomics and its friendly shape, make Lottus chair a versatile product and wide range of application, whether in the most demanding contract as well as in the home.

During the process of design, production, editing and marketing of LOTTUS tried to minimize the number of components in the seat, as well as reduce and replace the use of dangerous materials or negative environment.

3.1. Product specifications

	MATERIAL	Kg.	%
Chair	Steel	2.35444	40.93%
	Polyethylene	0.0086	0.15%
	Polypropylene	3.23	56.14%
	PVC	0.16	2.78%
Package	Polyethylene	0.14	8.93%
	Cardboard	1.4275	91.07%

3.2. Lottus life´s cycle.

At the end of life stage referred to different final destinations of the materials that make up the product.

This phase takes into account the transport of materials from their place of origin and have suffered some kind of transformation. For the calculation is included in the phase of MANUFACTURE.

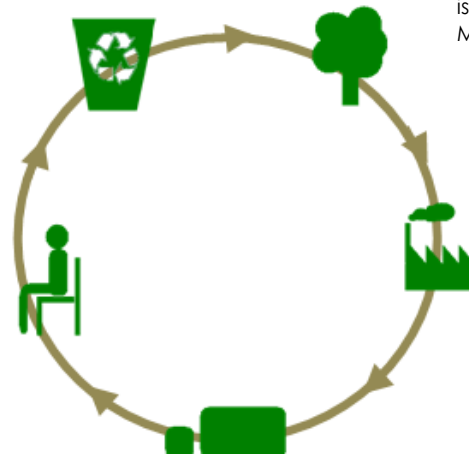

In the phase of use does not need any special maintenance, clean with soap and water, and estimating the useful life of a chair of this type in 10 years, these materials will be negligible compared to the other in the Analysis of the Life Cycle, so it is not included the use phase in LCA.

At this stage are recorded the Transformation that take place in the purchased raw materials to give rise to the product that ENEA offers.

This phase takes into account both packing needed to transport the product as the transport of the product itself. For the calculation is divided in two stages PACKING and TRANSPORT.

3.3. Environmental impacts.

Enea uses environmental software LCAManager, which allows obtaining values for different categories of environmental impacts using various methodologies. In LOTTUS we have calculated values for impacts according to the metodologia

- **CML2011:** Impact calculation methodology developed by the Centre of environmental sciences of the University of Leiden-Holanda..
- **Ecoidicator95:** Dutch Ecodesign methodology defined PRE CONSULTANTS. Provides unique value added categories of environmental impact (Goedkoop, 1995).
- **Ecoidicator99:** Dutch ecodesign methodology defined PRE CONSULTANTS. Provides unique value added categories of environmental impact (Goedkoop and Spriensmaa, 1999).

CATEGORY	Metodology	Units	Total Value
Global Warming (GWP)	CML2001	Kg CO ₂ -eq.	19.9
Reduction of the Ozone Layer	CML2001	Kg CFC11-eq.	2.87x10 ⁻⁶
Acidification	CML2001	Kg SO ₂	7.47x10 ⁻²
Photochemical oxidants	CML2001	Kg ethen-eq	5.34x10 ⁻³
Eutrophication	CML2001	Kg NOx-eq.	5.54x10 ⁻²
Heavy Metals	Eco indicador 95	Kg Pb-eq.	2,56E-06

3.4. Instructions for end-of-life of the product

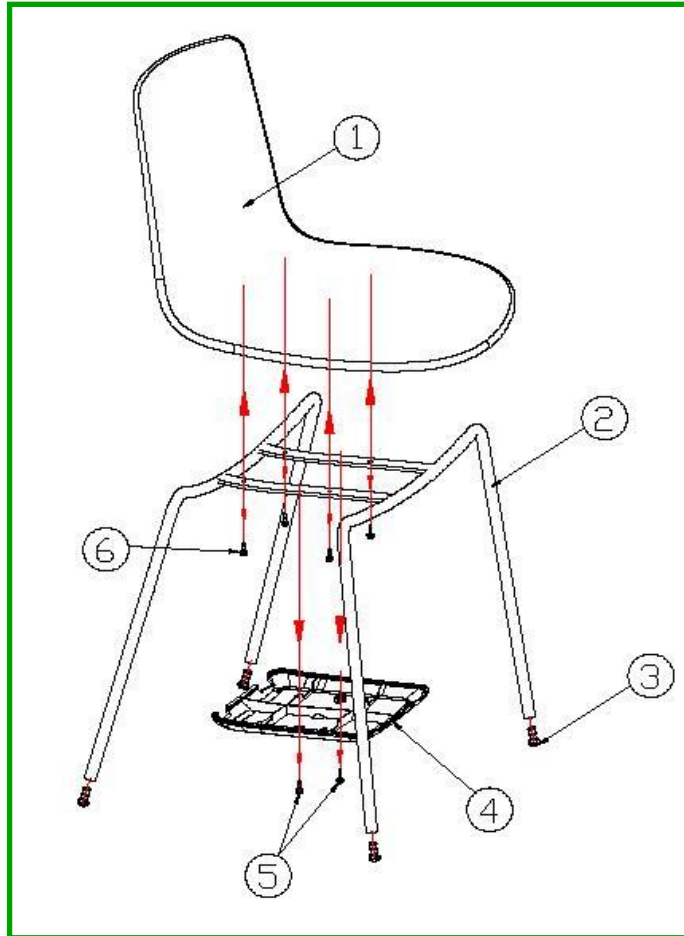

COMPONENT	MATERIAL	TARGET OF END OF LIFE
1	PP	Recycable
2	Steel	Recycable
3	Polyetylene	Recycable
4	PP	Recycable
5	Galvanised Steel	Recycable
6	Galvanised Steel	Recycable

3.5. Additional environmental information

- The product is suitable for reuse.
- The foams have not been manufactured with CFC or HCFC
- All plastic parts weighing more than 50g are marked according to ISO 11469 facilitating their classification for recycling.
- ENEA guarantees the availability of pieces at least 5 years, which avoids their removal and allows you to continue to use with minimal impact when compared with the manufacturing of a new chair.
- The 100% of the steel used is recycled.
- Approximately 10 percent of the plastic used is recycled.
- The materials used are 100% recyclable at the end of its useful life.
- The packaging is made of easily separable materials.
- The paints and lacquers used do not contain aromatic solvents or carcinogenic substances harmful to the reproductive system, mutagenic, toxic or allergenic according to Directive 1999/45/EC.
- The used plastic items do not contain heavy metals and phosphates.
- The waste generated is removed by authorized waste management enterprises.



Eco-design criteria

Diseño Design for the expansion of functions, multifunctionality, modularity and stackable, despite its apparent simplicity.



Design for reuse and recycling, ensuring easy removal and the use of recyclable and recycled materials.

Design for the reduction of use of materials, specially dangerous for human health and the environment.



**Environmental Memory –
LOTTUS WOOD**

Environmental Memory – LOTTUS WOOD

Index

1. General Information	Pág. 03
2. Enea with the environment	Pág. 03
3. LOTTUS WOOD: aspects of environmental innovation	Pág. 04
3.1. Specifications of the product	Pág. 04
3.2. LOTTUS WOOD life's cycle	Pág. 05
3.3. Environmental impacts	Pág. 06
3.4. Instructions for end-of-life of the product	Pág. 07
3.5. Additional environmental information	Pág. 08

1. General information

Product: LOTTUS WOOD

Designer: LIEVORE, ALTHERR, MOLINA.

2. Enea with the environment

ENEA started in 1984 focused to manufacture and market contemporary design furniture. During all these years it had an excellent evolution, with an important presence in the world market furnishing lots of unique buildings in the hands of renowned architects.

The company, in the manufacture of its products, shows its concern for the natural environment through a philosophy of design and production where the following environmental criteria are taken into account:

- **Simplicity:** during the design process seeks to minimize the number of components, achieving a perfect interplay between them.
- **Recycling and reuse:** design seeks the use of recyclable and recycled materials for their manufacture, as well as easy removal that would facilitate the recycling and reuse.
- **Use of non-dangerous materials:** ENEA also works to reduce and replace the use of dangerous materials or negative for the environment. For example, using epoxy paints that are free from solvents and compounds volatile organic harmful.

ENEA uses a few production processes of high technology, in addition to an intense process of research and adaptation of materials to the needs of use. Various processes have been submitted from the beginning to a rigorous policy of quality, what has led to the company to be one of the first Spanish companies, manufacturers of furniture design, in obtaining the **ISO 9001 quality certification** and certificate of the **system of management of ecodesign**, awarded by AENOR, complies with the **UNE-EN ISO 14.006** and the certificate of the system of environmental management according to the **quality certification UNE-EN ISO 14001**.

All these processes, controls and selection of materials, guarantee the high quality of the products of ENEA, both in strength and durability as its finish, but with the commitment to achieve all this, taking into account the environment, framed within sustainable development. The objective is always meet current needs without compromising future resources.

3. LOTTUS WOOD, aspects of environmental innovation.

Lottus Wood is an evolution of Lottus program, designed by Lievore Altherr Molina, that with the structure made of birch plywood, offers a product with character, friendly and warm to the most demanding public installations, hotel or home. Lottus Wood is a family consisting of the set of stool, chair and table in wood structure started in 2012 with the development of the chair with polypropylene shell and wood structure. In 2013 the group is completed with the stool and table, this latter available with laminate worktop. The design allows multiple combinations as Lottus Wood, always performed over a structure in natural or stained birch plywood, is available with polypropylene shell of different colours (single colour or bicolour) full or partial upholstered or wooden shell 3D . Lottus Wood Family offers contemporary and _timeless design, and is produced under ecodesign and environmental parameters and wood from sustainable forests with all current certificates. Thanks to its studied ergonomics, nice shape and wood finish, Lottus Wood is a global and versatile program which gets warm environments and atmospheres, whether in private or public establishments.

During the process of design, production, editing and marketing of LOTTUS WOOD tried to minimize the number of components in the seat, as well as reduce and replace the use of dangerous materials or negative environment.

3.1. Product specifications

MATERIAL	Kg.	%
P R O D U C T		
Steel	2,52	28,59152692
Zinc Plated Steel	0,0008	0,009076675
Polyethylene	0,01	0,11345844
Polypropilene	2,25	25,52814904
Wood	1,38	15,65726474
P A C K I N G		
Plastic	0,055	0,624021421
Cardboard	2,52	28,59152692
Foam (PE)	0,078	0,884975833

3.2. LOTTUS WOOD life's cycle.

At the end of life stage referred to different final destinations of the materials that make up the product.

This phase takes into account the transport of materials from their place of origin and have suffered some kind of transformation. For the calculation is included in the phase of MANUFACTURE.

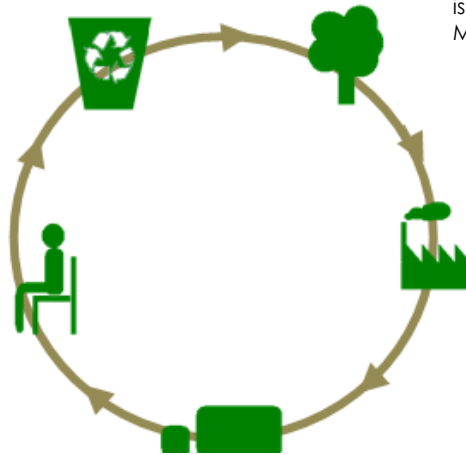

In the phase of use does not need any special maintenance, clean with soap and water, and estimating the useful life of a chair of this type in 10 years, these materials will be negligible compared to the other in the Analysis of the Life Cycle, so it is not included the use phase in LCA.

At this stage are recorded the Transformation that take place in the purchased raw materials to give rise to the product that ENEA offers.

This phase takes into account both packing needed to transport the product as the transport of the product itself. For the calculation is divided in two stages PACKING and TRANSPORT.

3.3. Environmental impacts.

Enea uses environmental software LCAManager, which allows obtaining values for different categories of environmental impacts using various methodologies.

In **LOTUS WOOD** we have calculated values for impacts according to the methodology:

- **CML2011:** Impact calculation methodology developed by the Centre of environmental sciences of the University of Leiden-Holanda..
- **Ecoidicator95:** Dutch Ecodesign methodology defined PRE CONSULTANTS. Provides unique value added categories of environmental impact (Goedkoop, 1995).
- **Ecoidicator99:** Dutch ecodesign methodology defined PRE CONSULTANTS. Provides unique value added categories of environmental impact (Goedkoop and Spriensmaa, 1999).

Category	Metodology	Total Value
Climate change (kg CO2 eq.)	CML 2001	3,63279398
Acidification (kg SO2 eq.)	CML 2001	0,025358586
Destruction layer ozone (kg CFC-11 eq.)	CML 2001	9,25208E-07
Photochemical oxidants (kg ethylene eq.)	CML 2001	0,000596271
Eutrophication (kg NOx eq.)	CML 2001	0,01529242
TOTAL (points)	Eco indic.99	0,396352905
Climate change 20 years (kg CO2 eq.) 20 years	IPCC	3,530371482
Climate change 100 years (kg CO2 eq.) 100 years	IPCC	3,632521976
Climate change 500 years (kg CO2 eq.) 500 years	IPCC	3,612140326

3.4. Instructions for end-of-life of the product

COMPONENTE	MATERIAL	DESTINO FIN DE VIDA
1	Polypropilene	Recyclable
2	Steel	Recyclable
3	Zinc Plated Steel	Recyclable
4	Zinc Plated Steel	Recyclable
5	Wood	Recyclable
6	Zinc Plated Steel	Recyclable
7	Polyethylene	Recyclable

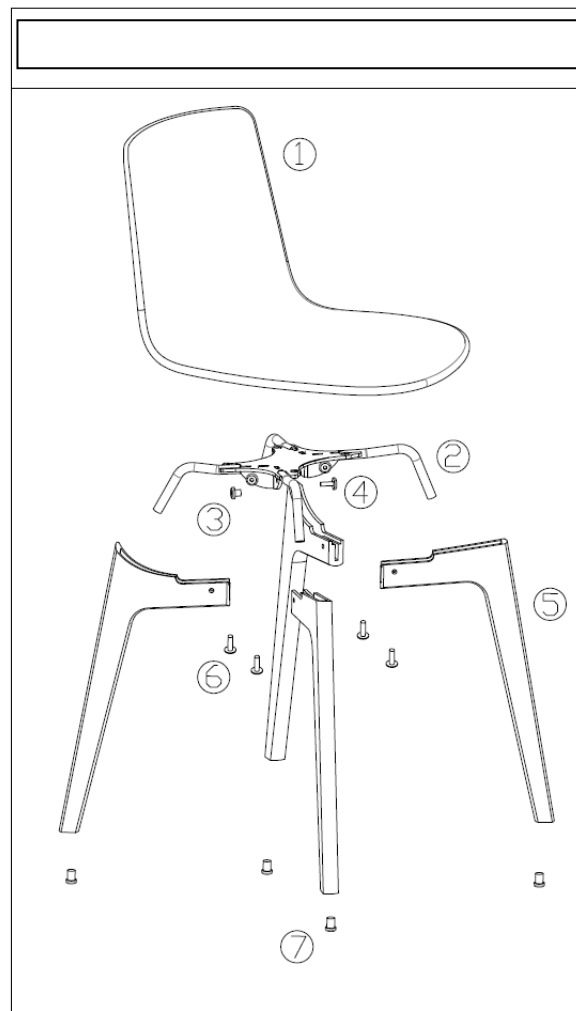

3.5. Additional environmental information

- The product is suitable for reuse.
- The foams have not been manufactured with CFC or HCFC
- All plastic parts weighing more than 50g are marked according to ISO 11469 facilitating their classification for recycling.
- ENEA guarantees the availability of pieces at least 5 years, which avoids their removal and allows you to continue to use with minimal impact when compared with the manufacturing of a new chair.
- The 100% of the steel used is recycled.
- Approximately 10 percent of the plastic used is recycled.
- The materials used are 100% recyclable at the end of its useful life.
- The packaging is made of easily separable materials.
- The paints and lacquers used do not contain aromatic solvents or carcinogenic substances harmful to the reproductive system, mutagenic, toxic or allergenic according to Directive 1999/45/EC.
- The used plastic items do not contain heavy metals and phosphates.
- The waste generated is removed by authorized waste management enterprises.



Eco-design criteria

Design for the expansion of functions, multifunctionality, modularity and stackable, despite its apparent simplicity.



Design for reuse and recycling, ensuring easy removal and the use of recyclable and recycled materials.

Design for the reduction of use of materials, specially dangerous for human health and the environment.